

1983

Not A Success—But a Triumph: 80 Years Since Kitty Hawk

Richard K. Smith

Follow this and additional works at: <https://digital-commons.usnwc.edu/nwc-review>

Recommended Citation

Smith, Richard K. (1983) "Not A Success—But a Triumph: 80 Years Since Kitty Hawk," *Naval War College Review*: Vol. 36 : No. 6 , Article 3.
Available at: <https://digital-commons.usnwc.edu/nwc-review/vol36/iss6/3>

This Article is brought to you for free and open access by the Journals at U.S. Naval War College Digital Commons. It has been accepted for inclusion in Naval War College Review by an authorized editor of U.S. Naval War College Digital Commons. For more information, please contact repository.inquiries@usnwc.edu.

Not A Success—But a Triumph: 80 Years Since Kitty Hawk

by

Richard K. Smith

So easy it seemed,
Once found,
Which, yet unfound
Most would have thought
Impossible.

—John Milton,
Paradise Lost,
Bk. IV.

On the Saturday afternoon of 8 August 1908 a select group of some three dozen persons gathered on the green of the Hunadieres race track near Le Mans, France. All had some association with aviation, such as it was. In 1908 aviation was less a science than a hope, it had more aspects of an expensive sport than any relationship to practical engineering. Nevertheless, there was a widespread conviction that mechanical flight was like a sun loitering beneath the horizon—dawn was inevitable—but when? These persons had assembled at Hunadieres to witness a demonstration of Mr. Wilbur Wright's flying machine and most of them did not expect to see much.

Everyone knew that less than three dozen airplane flights had been made since Alberto Santos-Dumont's exciting exhibition of 23 October 1906 when he lunged through the air for seven seconds, covering a distance of 60 meters; and on 12 November he flew 220 meters in 21 seconds. But of course, these were the first successful flights ever made by a heavier-than-air flying machine. Other flights had been made since and their durations and distances had not been much greater—on 9 November 1907 Henri Farman flew for 74 seconds and over more than one kilometer. What is more, on 13 January 1908 Farman not only flew for 88 seconds but his flight described a complete circle and returned to its starting point, covering some 1,500 meters over the

ground. This was the first circular flight ever made. It won Farman a prize of 50,000 francs, equal to ten thousand American dollars; it demonstrated the airplane's promise as a means of practicable aerial navigation. *The Times* of London hailed it as "epoch making." To be sure, it is unlikely that Mr. Wright will surpass Henri Farman's performance.

As we know, Mr. Wright and his brother have claimed to have flown in 1903 and to have perfected their machine during 1904 and 1905. There is a wealth of superficial evidence which suggests that they have indeed flown, in fact many times, but no one has witnessed these alleged flights. That is, no persons of consequence. Mr. Wright brought this machine to France in 1907 and he planned to demonstrate it in that year, but it is said that he was afflicted by many commercial complications relating to the sale of the invention, and for the past year this machine was stored in a customs warehouse in Le Havre. He returned to France in May 1908, retrieved the machine from storage, and has since been preparing it for this demonstration.

It is a curious machine and not at all like those in Europe. The surface which provides vertical control is in front of the operator instead of being part of the empennage. The operator is seated between biplanes with the engine directly beside him. Most provocative, there is a seat for a second person—apparently for a *passenger*! Perhaps its most odd aspect is that it has no wheels. Instead, it rests on a carriage which rolls along a monorail of 50 meters. A cable joins the carriage to a weight of 720 kilograms which is suspended in a tower. When the weight is released it draws the carriage forward with swiftness, accelerating the machine—and presumably assists it to attain flight. By means of chain drives, the 30 horsepower engine turns two propellers mounted at the rear of the wings. The propellers rotate in opposite directions, a novelty achieved by twisting one of the chain drives. Most remarkable is that Mr. Wright states that he has never before operated this particular machine.

It is now a trifle after 6 p.m. and—*attendez vous!* Mr. Wright has started his *moteur*. Monsieur Ernst Archdeacon, the president of the Aero Club de France is now pointing out to his associates the faults in the Wright machine and—*attendez!* Mr. Wright has increased the speed of his engine. He has released the weight in the tower. The machine is moving forward! It has left the rail! It is skimming across the earth—at a height of one, two, three meters—*il vole!*

But the small racecourse is bounded by a high tree line and the machine is headed directly for the barrier. *Mon Dieu!* A crash is inevitable. *Mais non!* The machine is turning to the left. It is saved! *Mais non!* it is tilting over on its side; it is sliding out of the air to earth. *C'est finis!*—*Non! Non! Attendez! Néanmoins,* it continues to move in this unbelievably dangerous angle and it is coming about through 180 degrees. *Incroyable!* And its height above the ground is even increasing! It is passing over our heads! *Fantastique! Magnifique!*

Mr. Wright circles *again*. The small circle of his turns is made with the machine tilted to an unbelievable hazard. It should fall out of the sky, but it does not. Mr. Wright is returning to earth. He touches down to the sod with the lightness of a feather. It all started so quickly, was done with such ease, and is finished so suddenly. *Les toutes incroyable! Nous sommes battus! Nous n'existons pas! Les Wrights regner en maître!*

For a moment the spectators stood as if frozen. In the next instant they were running toward the airplane. Men's eyes were filled with tears, their throats choked with emotions; there were sounds but few intelligible words. They embraced Wilbur and, in the French custom, kissed him on both cheeks. The moment dissolved into a babble of marvelous excitement.

The Europeans were not surprised that Wilbur flew. After all, Glenn Curtiss in America and Farman, Blériot, and Delagrange in France had been sputtering through the air in brief "flights" since 1907. What stunned Hunadières' spectators was how he flew—so effortlessly, rolling through breathtaking turns with such grace, obviously in absolute control, the machine being an extension of the man. This was flying as their imaginations thought it should be and, in a few seconds, Wilbur Wright showed them that their dreams were reality. What is more, from his dramatic mastery of the machine, it was manifest that the Wrights had been the masters of other men's dreams for some time. The Wrights' claims were true: *they had been flying for years!* The sun which they believed was procrastinating behind the horizon had long since been racing toward high noon, and its light was dazzling.

The flight's duration was 1.7 minutes, but in those 105 seconds, as the French aviator Louis Blériot put it, "a new era in mechanical flight has commenced—it is marvelous!" The Comte De LaVaux, a veteran balloonist and founder of the Fédération Aéronautique Internationale, described the Wright airplane as "this machine which has revolutionized the aviator's world." But it was the newspaper *Le Figaro* which seized the essence of the moment: "It was not merely a success, it was a triumph."

The eighth day of the eighth month of the eighth year of the 20th century framed Wilbur's moment, but it was the Wright brothers' finest hour.

A few days later on 3 September Orville Wright boarded a street car in Washington, DC, and traveled across the Potomac to Fort Meyer, Virginia, where he gave a similar demonstration. There was great excitement on the parade ground when Orville flew, but it did not approximate the hysterical enthusiasm which ran like wildfire throughout France and across Europe. The French newspapers splashed Wilbur's flights on their front pages; everything he did was news. The French were equally enthralled by Orville's flights 3,900 miles away in America. The American press treated Orville's Fort Meyer demonstrations as if they were a dull train wreck.¹

The respective national reactions to the Wrights' performances of 1908 set a curious precedent. From that day to this the Wrights' achievements have never been appreciated in the United States to the degree that they have in Great Britain and Europe. And there has always been a unique emotional bond between the French nation and its memory of Wilbur Wright.

At this point it may well be asked: but is it not 17 December 1903 and Kitty Hawk, North Carolina, which mark the Wrights' anniversary? Well, yes and no. History is invariably the product of a web of complexities, and anniversaries demand oversimplifications which permit speeches to be made in less than an hour. The Wrights' flights at Kitty Hawk in 1903 would have been impossible without what was done before, and they would have meant little without their work thereafter.

Popular American folklore continues to portray the Wrights as charming rustics who sold bicycles in Dayton, Ohio; they applied their "American genius" to the problem of flight and invented the airplane, succeeding where well-schooled men of science failed. Like most chauvinistic folklore, this popular legend holds few truths. More seriously, it does a terrible disservice to our memory of these two remarkable brothers.

In The Beginning Was The Toy

The Wrights' interest in flight apparently dates from a day in 1880 when their father made them a gift of a Pénau *hélicoptère*. At this time Wilbur was 13 years old, Orville was nine. The Frenchman Alphonse Pénau (1850-1880) designed and manufactured a series of ingenious model aircraft—helicopters, ornithopters, and airplanes—all of which were powered by twisted rubber bands which turned a propeller or a flapping device. It was Pénau who originated the twisted rubber band as a source of motive power. His creations flew; one of his little airplanes flew for 11 seconds and some of his helicopters rose to 20 or even 50 feet, flitting about for as long as 26 seconds before fluttering to earth. Over the past 100 years hundreds of millions of model builders have built Pénau machines, but few associate the origins of their pleasures with this Frenchman of the 19th century.

In later years the Wrights followed the gliding experiments of Otto Lilienthal in Germany during 1894-96. Although Lilienthal died as a result of a gliding accident on 8 August 1896, the brothers' interest in the subject only increased. Exhausting available literature on aeronautics, in May 1899 Wilbur wrote to the Smithsonian Institution for further information and the reply provided an extensive bibliography. They perceived the Smithsonian as their best source of information because of the experiments of its Secretary, Samuel P. Langley (1834-1906), in developing a flying

machine. Langley's work started in 1889, and in 1894 and 1896 he built large model airplanes powered by steam engines which made successful, if uncontrolled, flights of a few seconds. When Wilbur wrote to the Smithsonian it was generally known that Langley was working on a manned aircraft.

At this early date it already occurred to the Wrights that all efforts to develop flying machines had moved along one dimension only, the fore-and-aft axis of flight relative to altitude. There are three axes of flight: *pitch*, *yaw*, and *roll*. Thus far, would-be airmen had been concerned only with control in pitch; no one as yet had seriously addressed control in yaw and roll remained to be discovered. Lilienthal had sought lateral control by shifting the weight of his body, but the Wrights recognized this as a dead end. They perceived that lateral control, namely *control in yaw*, could be obtained aerodynamically by varying the angle of a wing's tips, the result being a variation in lift, and this should serve to provide balance and turn the machine. In that summer of 1899 they built a large kite, a biplane structure with a five-foot wingspan. The whole structure could be twisted, its wing tips flexed, controlled by separate cords. The kite's performance was satisfactory and they moved toward the design of a manned glider.

In 1900 they determined that favorable wind and vast areas of clear ground existed at Kitty Hawk on North Carolina's desolate Outer Banks. In September they traveled to Kitty Hawk with a biplane glider (17.5 ft. span; 165 ft.² wing area), which they flew as a kite—manned and unmanned—and in free flight. Their "flights" were of only a very few seconds' duration and in the month they spent there, their total flying time was three minutes. Admission of ignorance is the beginning of wisdom. The Wrights were never embarrassed by their ignorance, and at Kitty Hawk they discovered that they had much to learn.

In 1901 they returned to Kitty Hawk with a new glider (22 ft. span; 290 ft.²). It was another season of disappointments, frustrations, and new problems which they were hard put to identify. Two things were certain: (1) to date they had relied on Lilienthal's aerodynamic data and something was terribly wrong with it; and (2) their own idea of wing-warping to achieve lateral control wanted for something. After six weeks they returned to Dayton with suspicions of defeat.

Convinced that there were serious flaws in Lilienthal's data, they became determined to identify those flaws and determine what was correct, so in the winter of 1901-02 they built a wind tunnel. It was six feet long, its throat 16 inches square, and because their shop had no electricity (gaslight only), its fan was powered by a small internal combustion engine. The world's first wind tunnel was built by Francis H. Wenham (1824-1908) of England in 1871, and the brothers were familiar with his many published works. They tested more than 200 airfoils and wing configurations, determining that most published

data was far too optimistic. They devised airfoils of their own design and determined the virtues of high-aspect ratio, i.e. a wing platform of small width relative to its span.

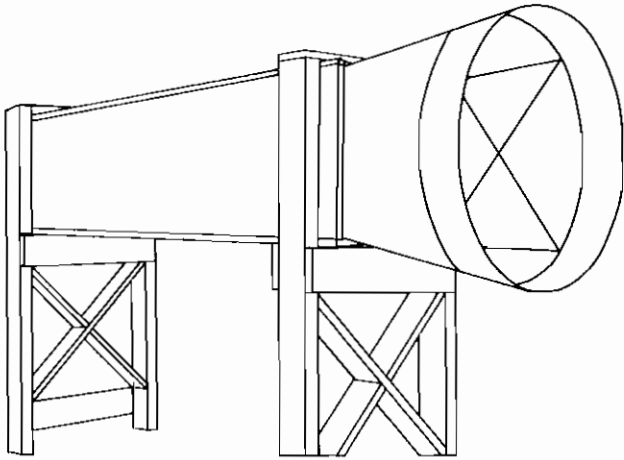

WIND TUNNEL: Although the original Wright Wind Tunnel was “lost,” this is an artistic version of a reconstructed model. (Artist: Gerard Lamothe, NWC.)

The Third Dimension of Flight

In August 1902 they returned to Kitty Hawk with a wholly new biplane glider (32 ft. span; 305 ft.²), which at this date was the largest glider in the world. Like their previous gliders, this one had its elevator surfaces in front of the wing. While this seems odd today, it provided the Wrights with an optical reference to the horizon and, aerodynamically, its position provided far more positive control than if it had been made part of a tail. Their experiences of 1901 suggested the need of a vertical stabilizer and the 1902 glider had a tail structure with two fixed stabilizers.

They spent two months at Kitty Hawk. Until this time they thought that their wing-warping should be enough to turn the glider. But it only seemed to initiate a turn, and then with confusing results. They finally decided that a rudder was necessary to aerodynamically balance and accelerate the machine through its turn, and the vertical stabilizers were changed to a single movable surface.

Now they had an elevator up front, aileron-results from their wing-warping, a tail with a rudder. Equally important, they had more than two years' experience behind them. They were now ready to fly. Whereas their two previous Kitty Hawk seasons had been filled with frustrating problems and relatively few flights, in 1902 they made more than a thousand successful gliding flights. The longest was 26 seconds over a distance of some 620 feet,

more than twice the length of a football field. During these flights they soon determined that a combination of rudder and wing-warping (ailerons) provided the best control, thereby discovering the third dimension of flight, namely *control in roll*.

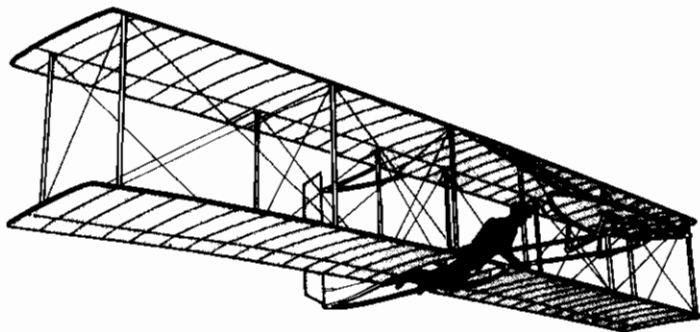

Wright 1902 glider: During excessive banking, the original 1902 glider had an alarming tendency to fall off in a steep, diving turn—"well digging" as the Wrights termed it—due to drag caused by wing warping combined with fixed rudder leverage. They therefore modified the machine, replacing its fixed double rudder with a movable single rudder connected by cables to the pilot's hip cradle, which controlled wing warping. Complete control was thus at last attained.

The 1902 season was a phenomenal success. They had divined the three elements of control; it now remained to put a source of power in the machine so they could extend their flying time from seconds to minutes and test their findings at length. During the winter of 1902-03 they set about the creation of a powered airplane. Meanwhile, they considered their experiences of 1902 as sufficiently conclusive that on 23 March 1903 they applied for a patent on their "Flying Machine" and the principles of their control system. This is the basic Wright patent; its application antedates the first powered flights by nine months.

Although their 1903 airplane was essentially a scaled-up variant of the principles embodied in the 1902 glider, its construction proved to be far more complicated than anticipated.

They could find no engine of a remotely acceptable power-to-weight ratio; all available engines, however small, were much too heavy. They designed and built their own engine. It had an aluminum block with four separate cast iron cylinders, a 4-inch bore with 4-inch stroke, delivered 12 hp. at 1025 rpm, and weighed 180 lb.; the ratio is 15 lb. per hp.

The Wrights discovered that there was not the smallest body of technical data about the design of airplane propellers and that which related to marine propellers was useless. Realizing that an airplane propeller is practically an airfoil rotating around a fixed point, they used their airfoil data to design and manufacture their own propellers.

The *Flyer I* which they took to Kitty Hawk in 1903 was only a trifle more than a powered glider. However, this estimate is based on hindsight. In 1903 it was the world's first and only airplane, and every aspect of its creation was owed to the Wright brothers. It is sometimes said that they did everything except grow the trees which produced the wood for their airframe.

Success

It took weeks to assemble the machine and test its engine. Then the malign weather of an early winter swept out of the Atlantic, lashing the Outer Banks with 80-knot winds. Test runs revealed serious faults in the engine and its accessories; the propeller shafts had to be redesigned and taken back to Dayton for remanufacturing—not once, but twice.

On 14 December the weather cleared and the *Flyer I* was taken out for its first flight. Looking at history through the “wrong end of the tube,” the Wright airplane seemed strange for its lack of a wheel landing gear. But the Wrights were extraordinarily rational men; they did not build their airplane to be rolled around the ground, they designed it to fly. And at this stage of development wheels were a complication they did not need. Instead, the airplane sat on a carriage on a 60-foot monorail laid in sections on the ground. The rail not only guided a takeoff, it reduced friction and eliminated the problem of uneven terrain. For landing, the airplane alighted on a pair of skids which were an inherent part of its airframe.

Wilbur made the flight of 14 December. After a 40-foot run the machine lifted clear of the rail. But Wilbur overcontrolled and climbed too steeply (this was also *his* first flight!); after 3.5 seconds and covering 112 feet in distance, the airplane settled to the ground with minor damage.

This “flight” would have been more than enough to please most would-be aviators of 1903. But not the Wrights. They were always their own toughest critics. They refused to count this experience as a “flight” and as a result little is ever heard of it.

Nevertheless, this apparently ephemeral experience was informative enough to Wilbur that he wrote to his parents that same evening: “There is no question of final success.” And on the 15th Orville telegraphed their parents: “Success assured.”

On 17 December, the date which is enshrined in the history books, they made four flights (see figure 1). What is noteworthy here is the number of four consecutively. No other would-be aviator of 1903-08 ever made four flight efforts in a single day, much less within three hours. What this reveals about the Wrights is that, from the first, they knew that everything was going as they had anticipated; they simply required a repetition of the experience to collect more data. What it says about the others is that one experience (maybe two), was enough to tell them that everything was terribly wrong, there was no point in pursuing the effort further. It was time

to go “back to the drawing boards.” But the answer which these would-be aviators sought, and which the Wrights found, was not on any drawing board; it existed only in the experience of flight.

Figure 1
The Flights at Kitty Hawk, 17 December 1903

Flight No.	Pilot	Time of Day	Flight Duration, Seconds	Distance Over The Ground, Ft.
1.	Orville	10:35	12	120
2.	Wilbur	11:20	11	175
3.	Orville	11:40	15	200
4.	Wilbur	12:00	59	852

The Wrights planned on making at least one more flight this day, hoping to fly from their takeoff point near Kill Devil Hill to the tiny community of Kitty Hawk four miles away. This would have been a sensation. But a gust of wind seriously damaged the airplane. The season was late, winter was upon them, and they gave it up for 1903. They sent a telegram to their father: “Success four flights Thursday morning. All against twentyone mile wind started from level with engine power alone speed through air thirtyone miles longest 57 seconds inform press home Christmas.” There are three noteworthy items here. One is the error of “57” for which should have been “59.” Far more significant is the word “success.” The Wright family never did a traffic among themselves in reciprocal fantasies, and when the brothers said “success” they meant “*Success!*”

As difficult as it may be for all later generations to fully appreciate, the Wrights’ total of 97 seconds in the air confirmed for them all of their labors of the previous four years. They knew well that the *Flyer I* was not a practical airplane. But now they knew how to go ahead with such a vehicle, as they would in 1904 and 1905.

The third aspect of the telegram worth noting is in the words “inform press.” The Wright family did inform the press and later the brothers sought to inform the press; yet their information was brushed aside.

A reason for the Wrights being given such short shrift is that only nine days before their success at Kitty Hawk, Professor Langley of the Smithsonian experienced disaster with his flying machine. Immediately after launching, it plunged into the Potomac River. Newspaper reporters who were present compared its flying characteristics to “a handful of mortar.” And this was its second disaster; in October it had done the same thing. The Langley machine was an abortion of an airplane, an utter fiasco. It cost the US Government \$75,000, a substantial sum in a day when \$15 a week was good pay. If Professor Langley of the Smithsonian could not build a flying machine with

the resources of the US Government, who could believe that two young men from Ohio might have succeeded where Langley failed? December 1903 was no time for anyone to assert that they had created a successful flying machine. However, this does not explain the news media's treatment of the Wrights in years subsequent to 1903.

Until the 1920s when commercial radio broadcasting penetrated American life there were no news media, only a medium, and it was the newspaper. But if there had also been radio and television during 1903-1908, it can only be imagined that they would have made a greater hash of the dawn of mechanical flight. The press completely bungled the story of the Wrights, not only in 1903, but repeatedly during the five years of 1904-08. The relationship between the Wrights and the news medium of their day is one of the most grotesque stories of the 20th century and it was by no means the fault of the Wrights.

The Incredible Years

In 1904 the brothers built a new airplane, the *Flyer II*. Confident that they no longer needed the winds and space of Kitty Hawk, they sought an airfield nearby to Dayton. In 1904 Dayton's population was less than 100,000, it was not a city overflowing with anonymities; and the Wrights were among the city's better known and most respected businessmen. They went to Torrance Huffman, the president of Dayton's Fourth National Bank, and obtained his permission to use a 90-acre tract of pasture land he owned eight miles east of the city. Huffman was agreeable, and he did not charge the brothers a dime.

This piece of property (long since swallowed up by Wright-Patterson Air Force Base), was known as Huffman Prairie. It was sited between two well-traveled highways and adjacent to an interurban trolley line that ran between Dayton and the small town of Fairfield. The Wrights chose to erect a shed which was the base of their operations, and located nearby was a regular stop on the trolley line known as Simms Station. If they wanted to conduct their flying experiments in secrecy, they would have been hard put to choose a worse place.

In 1904 they made 105 flights, most of them being brief test flights of 30 seconds or less; but by the end of the season their total flying time was 45 minutes. Most of their flying was done after 1 September, their airplane performing badly when it performed at all in the hot, thin, and humid air of summer at Dayton's elevation of 715 feet above sea level. The fickleness of the wind inspired them to create their catapult, the "starting derrick" as they called it. On 20 September Wilbur flew the first 180-degree turn by a heavier-than-air flying machine, returning to the approximate point of his takeoff. Hereafter, circular flights were made with frequency. This was simply a matter of practicality; it avoided the necessity of having to drag the

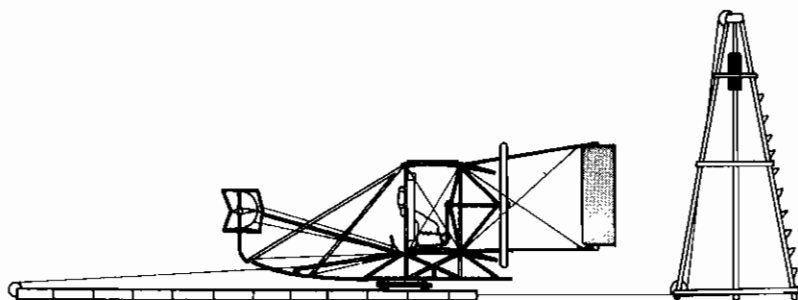

Takeoff assistance: This sketch shows arrangement of the unique weight-and-derrick launching device first used in September 1904. Subsequent tower sizes, drop weights, and rail lengths varied somewhat. When the weight dropped, the machine was pulled rapidly along its rail, and, as it neared the end, the pilot raised the nose. At that instant the rope released itself and the airplane took off.

In the summer of 1905 they returned to Huffman Prairie with their new *Flyer III*. In external appearances it was not significantly different from its forebears, but many refinements had been worked into it and it was a far more versatile flying machine (see figure 2). The Wrights regarded the *Flyer III* as marking the end of their purely experimental efforts and historians are unequivocal in acclaiming it as the world's first practical airplane. Forty-nine flights were made, the longest by Wilbur who on 5 October flew 29 circuits of the field within 38 minutes. In this season they logged a total of three hours in the air.

Figure 2
The Wright Airplanes, 1903-1905

	Flyer I 1903	Flyer II 1904	Flyer III 1905
Gross Weight, lbs.	765	925	1,050
Tare	605	675	710
Disposable Load	160	250	340
Load: Tare	20:80	27:73	32:68
Wingspan, ft.	40'04"	40' 04"	40' 06"
Wing area, ft. ²	510	510	503
Wing loading lb./ft. ²	1.5	1.8	2.0
Horsepower	12	16	20
Power Loading lb./hp.	63.7	57.8	52.5

There is an aspect to these flights which is absolutely bizarre. All flying was done within sight of two highways and an interurban railway which had a trolley car passing every few hours. Literally hundreds of people saw the Wrights buzzing around the treetops of Huffman Prairie, and yet the world declined to take notice. The Digby stories traveled around Dayton by word-

of-mouth and dozens of persons were moved to call the newspapers, asking why there was no news about the flying machine at Simms Station. The editors refused to attach any importance to "rumors," they regarded such calls as a nuisance, and no reporters were given trolley fare for a trip to Simms Station.

Word nevertheless spread. There was a Mr. A.I. Root of Medina, Ohio, some 180 miles northeast of Dayton. He heard about the Wrights; he traveled to Huffman Prairie to verify the stories, and he was present when Wilbur flew the first 180-degree turn. Root was in the apiary business and was the publisher of a magazine called *Gleanings in Bee Culture*.² In its issue of 1 January 1905 he published an enthusiastic but thoughtful five-page article which described what he saw near Dayton and he discussed its portents. A copy of this article was sent to *The Scientific American* whose editors dismissed it with rudeness.

On 16 October the Wrights made their last flight of 1905's season and they did not fly again until two and one-half years later on 6 May 1908, when they refreshed their flying skills for that year's demonstrations. Why did they ground themselves for 931 days? The reasons are complex. Most important was that their patent (US No. 821,393), was still pending; it was not granted until 22 May 1906.³ Meanwhile, it was on file in the Patent Office where anyone could examine its data. The Wrights were confident that the patent data alone would not readily unlock their secret, which in truth was less an "invention" than a *discovery*; the data had to be combined with flight experience. But as they progressively mastered flight, they grew to appreciate the magnificent simplicity of their achievement. A person knowledgeable in the day's crude aeronautics might be able to combine the patent's information with careful observations of their flying, thereby unraveling enough of the mystery of mechanical flight to advance them to the position where the Wrights had been in 1902, maybe even 1903. This was a risk they could not afford to take.

In October 1905 the Wrights became aware of being spied upon. Whereas most spectators to their flying came forward and identified themselves, they began to notice men lurking at a distance who were observing their operations through binoculars. This was an inspiration toward secrecy. Concurrently, they were engaged in negotiations with the governments of France and Great Britain, and with the US War Department, for the sale of rights to their airplane. This was a convoluted, aggravating, and frustrating process of two years. And they were busied by building new demonstrator airplanes, one of which they took to France in 1907 and was left stranded in a warehouse for a year as the result of stalled business arrangements. Yet another machine was built for the US Army. And they were running their bicycle business. They had more than enough demanding activities to fill their days without commuting to Huffman Prairie.

Horsepower on a Barn Door

While the Wrights were mired in business affairs, aviation experienced a dramatic revival in Europe, initially in terms of the lighter-than-air airship, and then in efforts to develop an airplane. In anticipation of great events, the Fédération Aéronautique Internationale was created on 14 October 1905; it defined measures and established rules for “record flights” and provided observers to confirm performances as it still does more than three-quarters of a century later.

In 1906 Santos-Dumont made his celebrated uncontrolled lunges through the air and all Europe was certain that these were the world’s first “flights” by a heavier-than-air machine. In 1907 Charles Voisin, Horatio Phillips, Louis Blériot, Henri Farman, and Robert Esnault-Pelterie started hopping through the air, all doing well to exercise a precarious control in pitch. Then in early 1908 Farman flew his sensational circles, stuttering through his turns like a pig on roller skates, turning by rudder alone; but he demonstrated a tenuous control in yaw. No one but the Wrights as yet had any conception of control in roll. Indeed, the very idea of deliberately rolling an airplane on its axis would have struck the Europeans as suicidal.

Whereas the Wrights first taught themselves how to fly by gliding, working out control systems in their gliders, and only then built their airplane, the Europeans and other Americans were building powered machines which by their calculations should be capable of flight, and then tried to determine how the machines might be flown. When it is appreciated that none of these men knew how to fly nor as yet had any conception of the proper technique, this “method” was infinitely more awkward than the Wrights’—and dangerous to life and limb.

The late Charles H. Gibbs-Smith (1909–1981), a British historian who devoted half his lifetime to the subject of early aviation, shrewdly observed that the Europeans treated their flying machines as they would an automobile. They suffered from a “chauffeur” mentality, expecting to gain altitude and then “drive” the airplane through the air in only two dimensions as they would along a highway. He divides the early aviators into “chauffeurs” and “fliers,” and prior to 1909 there were only two “fliers” in the world: Wilbur and Orville Wright.

In 1901 Wilbur Wright remarked of flying: “If you are looking for perfect safety you will do well to sit on a fence and watch the birds, but if you really wish to learn you must mount a machine and become acquainted with its tricks by actual trial.” In 1906 the Europeans started mounting their machines and by 1908 they were learning by trial. Wilbur also remarked that if enough horsepower was applied to a barn door, it would fly—for awhile, at least. European aero engines were far superior to the Wrights’, often possessing more than twice as much horsepower. Whereas the Wrights taught themselves to fly by gliding, the Europeans were learning how to fly by

dragging themselves through the air by horsepower. They would eventually, but inevitably, identify and resolve the problems which the Wrights had mastered by the end of 1902.

In the summer of 1908 the Wrights laid public claim to their great achievement none too soon. By 1909 or 1910 they would have achieved a public success, but it is unlikely that the experience could have been remotely similar to their triumph of 1908.

L'envoi Triste

The patent by which the Wrights set such great store proved to hold less joy than headaches and heartaches. They discovered that a patent does not provide ironclad protection, that it is only a little more than a license to sue, and they endured almost a decade of bitter litigation. The Wrights won all their lawsuits, only to discover that it was yet another matter to collect damages and royalties.

The Wrights' dilemma was in their own genius; they did not simply patent the "airplane"; in patenting the principles of their control system, they had patented *flight!* No one could build an airplane without infringing their patent and there was no practical means of keeping a discovery of such transcendence in a cage of legalisms. It was as futile as the efforts of Imperial Spain to build a fence around the discoveries of Christopher Columbus.

Wilbur died in 1912, only 45 years of age; Orville lived to see their airplane develop into a weapon of terrible portents during 1914-1918, to fly the oceans in years thereafter, establishing a global network of air transportation; and in 1945 he saw it become a vehicle of nuclear destruction. And in those same years he fought his own stubborn and lonely battle with the Smithsonian Institution against the latter's efforts to discount his and Wilbur's achievements.

Samuel P. Langley died in 1906 and those who succeeded to his place in the Smithsonian's red castle became determined to exaggerate his work in aeronautics for their own institutional glory. This could not be done without defaming the Wrights. In building their ridiculous case for Langley the Smithsonian's hierarchy even conspired with Glenn Curtiss, the Wrights' arch-rival and a defendant in the Wrights' most sensational patent suit which Curtiss lost. Curtiss engineered a well-publicized but wholly fraudulent demonstration which "proved" that the Langley machine *should* have flown in 1903, and the Smithsonian seized upon this alleged capability to give precedence to Langley. Well aware of the technical details, Orville could not possibly accept this.

This was a disgraceful affair, and as a result of a smug, self-serving bureaucracy's refusal to admit error, it dragged on for 32 years. It was not resolved to Orville's satisfaction until 1942.⁴

Meanwhile, in 1928 Congress moved to authorize the creation of a

memorial to the Wrights' flights at Kitty Hawk, a magnificent monument which was dedicated in 1932; however, private donations underwrote its design and construction. But the Smithsonian could not be budged from its position, and in 1928 Orville shipped the *Flyer I* aboard the liner *Minnewaska* to England on a long-term loan. On the 25th anniversary of their flights at Kitty Hawk the British were pleased to place the *Flyer I* on exhibit in a newly opened hall of the Science Museum in South Kensington, in ceremonies attended by King George V. The Smithsonian's selfish ignorance made the *Flyer I* an American treasure guarded by British wisdom for the next 20 years.

Although the dispute between Orville and the Smithsonian was settled in 1942, World War II made it inexpedient to return the artifact to the United States, and it was not returned until 1948. But even this was not a straightforward operation. Shipped as cargo aboard the Cunarder *Mauretania*, an American dock strike forced the liner to put into Halifax, Nova Scotia, where the airplane was off-loaded. The escort carrier USS *Palau* (CVE-122), transported the *Flyer I* to New York where on 19 November 1948, at the Bayonne Naval Annex, it finally returned to American soil.

On 17 December 1948 the *Flyer I* was formally placed on exhibit in the Smithsonian. Orville Wright was not present; he had died on 30 January 1948. No one should be moved to sentimental tears over Orville's absence. Both he and his brother regarded public ceremonies which honored their achievements as nuisances which they endured with polite silence. The brothers insisted upon the credits which were due them. That was a matter of accuracy and truth. But public ceremonies in which a corps of persons who had nothing to do with aviation carried on like a troop of dancing bears was quite another matter.⁵

Curiously, the efforts of agencies of the US Government to honor the memory of the Wrights have usually been convoluted when not shabby, backhanded, tardy, or ultimately degraded. The great Air Force installation near Dayton, Ohio, was originally named Wright Field in memory of the late Wilbur, but in 1948 this honor became compromised by the name of an obscure 1st lieutenant who had the bad luck to kill himself in a flying accident of 1918. In 1921 the Navy named its first seaplane tender the *Wright* (AV-1) in honor of the late Wilbur, but named its first aircraft carrier after the eminently unsuccessful Samuel Langley; and in 1943 a second *Langley* (CVL-27) was commissioned. The old seaplane tender was stricken after World War II and the name *Wright* was carried forward by the CVL-49, commissioned in 1947. As a ship type, the CVL had no enduring success; the *Wright* had a checkered career, and when decommissioned for a third and last time in 1970 she was functioning as a communications platform.

The Navy and the nation have never honored the Wright brothers by giving their name to a first-class aviation ship. In the rush to name ballistic missile submarines after "great Americans," the Wrights were overlooked.

This oversight is remarkable, perhaps not unusual, but it is fortuitous. Few things could be more bizarre than concealing the names of Wilbur and Orville Wright beneath forty fathoms of salt water. Although the naming of the Navy's ships has long since become disconnected from the nation's history and has degenerated into a noisy lottery among ephemeral political interests, perhaps in some year before the Wrights' 100th anniversary there will be launched a mighty aircraft carrier of some 90,000 tons which will bear the great name of *The Wright Brothers*. It is a gesture which is long overdue.

The Coattails of History

The final forms of recorded history often swing on the hinges of *ifs*. If the Wright Brothers had been killed in a train wreck while returning to Ohio in December 1903, and their airplane destroyed, the fate of their claims to flight would have been left in the memories of their few witnesses resident in the wilds of the Outer Banks; and today the souvenirs of their scientific and engineering labors would be regarded as no more than marvelous curiosities.

If Wilbur had died on 30 May 1908, instead of as he actually did on 30 May 1912, the demonstrations of 1908 could not possibly have happened as they did. Wilbur was always the prime mover in the brothers' unique relationship, both intellectually and as the man of action. Indeed, it is possible that Orville might have become so distraught (as he in fact did after Wilbur's death in 1912), that there might not have been any demonstration during that calendar year.

And if the brothers had not acted together when they did in 1908, other aviators, flailing their way through the air by brute power alone, would have inevitably discovered by experience the "third dimension" of flight, and the Wrights' meticulous work would have been placed at a discount, its unique achievement not illuminated until many years later. Even as events unfolded after the great excitement of 1908 drained away, the Wrights had more than enough difficulties in defending themselves against influential detractors who sought to defame their labors.

It may be said that in the summer of 1908 the Wrights had the wit to seize history by its coattails, transforming the garment's powerful threads into magnificent robes of investiture which legitimized the crown which became theirs at Kitty Hawk on 17 December 1903.

Notes

1. Being made late in the day on the 3rd, Orville's flight could not be given treatment until the 4th. Being morning papers, *The New York Times* and *The Washington Post* put it on page one; the *Washington Evening Star* was an afternoon paper and when it went to press the news was "old" so it was buried on page 3. None thought Orville's demonstration was worth a word of editorial comment.

2. The marvelous Root article is reprinted in full as an appendix to Charles H. Gibbs-Smith's *The Aeroplane: An Historical Survey of its Origins and Development* (London: H.M.S.O., 1960), pp. 235-239. The

magazine *Gleanings in Bee Culture* is still published by the A.I. Root Co. of Medina, Ohio; the year 1983 marks their 110th year in business.

3. Today anyone may obtain a copy of the Wright patent, *Flying Machine*, No. 821,393 (22 May 1906), by sending one dollar to the US Patent Office, 2021 Jefferson Davis Highway, Arlington, Va., 20231.

4. Fred C. Kelly, *The Wright Brothers: A Biography Authorized by Orville Wright* (New York: Harcourt, Brace, 1943), pp. 300-333, provides a good summary of the Smithsonian embroglio.

5. On 24 September 1908, when asked to make an after dinner speech in Paris, Wilbur stood up and said, "I know of only one bird, the parrot, who talks, and it can't fly very high"; and he sat down. This proved to be the Wrights' policy statement on contributing to the verbiage of public affairs.

A historian of flight, Dr. Richard K. Smith is the author of *The Airships Akron and Macon: Flying Aircraft Carriers of the United States Navy*, and the prize-winning *First Across: The U.S. Navy's Transatlantic Flight of 1919*, as well as a number of articles and book reviews for this and other magazines; he teaches a course in the history of mechanical flight at the Embry-Riddle Aeronautical University Extension in Washington, DC.

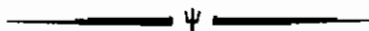

Colonel Robert D. Heintl, Jr. Memorial Award in Marine Corps History

The Marine Corps Historical Foundation has announced the criteria for the fourth annual Colonel Robert D. Heintl, Jr. Memorial Award in Marine Corps History. The award will be \$1,000 for the best article pertinent to Marine Corps history published in this or other similar journals in 1983.

Colonel Heintl, the distinguished Marine Corps officer, journalist, and historian whom this award memorializes, died in May 1979. Probably the best known of his many published works is his history of the Marine Corps, *Soldiers of the Sea*. He was a founder of the Marine Corps Historical Foundation.

In keeping with Colonel Heintl's great breadth of interest, "Marine Corps history" is very broadly defined for purposes of this award and includes biography and contemporary events. The key consideration is that the candidate article be *pertinent* to US Marine Corps history.

Announcement of the award winner will be made in the spring of 1984. Readers, in addition to the editors, are encouraged to nominate articles of their choice. The address is:

Colonel Robert D. Heintl, Jr. Award Committee
Marine Corps Historical Foundation
Bldg. #58 WNY, Washington, DC 20374